



MT8205 N - Channel

General Description

MT8205 uses advanced trench technology to provide excellent $R_{DS(ON)}$, low gate charge and operation with gate voltages as low as 2.5V. This device is suitable for use as a Battery protection or in other Switching application.

Product Summary

| | |
|------------------------------------|----------------|
| V_{DS} | 20 V |
| I_D (at $V_{GS}=4.5V$) | 6.0A |
| $R_{DS(ON)}$ (at $V_{GS} = 4.5V$) | < 25m Ω |
| $R_{DS(ON)}$ (at $V_{GS} = 2.5V$) | < 32m Ω |

Marking : 8205

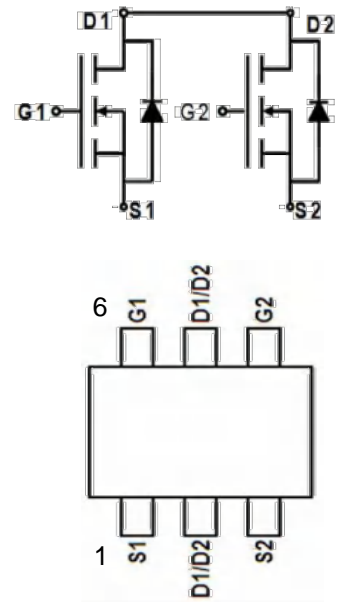

SOT23-6

| Absolute Maximum Ratings $T_A=25^{\circ}C$ unless otherwise noted | | | |
|---|----------------|------------|-------------|
| Parameter | Symbol | Limit | Unit |
| Drain-Source Voltage | V_{DS} | 20 | V |
| Gate-Source Voltage | V_{GS} | ± 12 | V |
| Drain Current-Continuous @ $T_J=25^{\circ}C$ | I_D | 6.0 | A |
| Pulsed ^b | I_{DM} | 20 | A |
| Drain-Source Diode Forward Current ^a | I_S | 2.5 | A |
| Maximum Power Dissipation ^a | P_D | 1.25 | W |
| Operating Junction and Storage Temperature Range | T_J, T_{STG} | -55 To 150 | $^{\circ}C$ |

| Thermal Characteristic | | | |
|--|-----------------|-------|---------------|
| Parameter | Symbol | Limit | Unit |
| Thermal Resistance, Junction-to-Ambient ^a | $R_{\theta JA}$ | 100 | $^{\circ}C/W$ |



Electrical Characteristics (TA=25°C unless otherwise noted)

| Parameter | Symbol | Condition | Min | Typ ^c | Max | Unit |
|---|--------------|--|-----|------------------|-----------|------------|
| Off Characteristics | | | | | | |
| Drain-Source Breakdown Voltage | BV_{DSS} | $V_{GS}=0V, I_D=250\mu A$ | 20 | - | - | V |
| Zero Gate Voltage Drain Current | I_{DSS} | $V_{DS}=20V, V_{GS}=0V$ | - | - | 1 | μA |
| Gate-Body Leakage Current | I_{GSS} | $V_{GS}=\pm 12V, V_{DS}=0V$ | - | - | ± 100 | nA |
| On Characteristics | | | | | | |
| Gate Threshold Voltage | $V_{GS(th)}$ | $V_{DS}=V_{GS}, I_D=250\mu A$ | 0.5 | 0.7 | 1.2 | V |
| Drain-Source On-State Resistance | $R_{DS(on)}$ | $V_{GS}=4.5V, I_D=4.5A$ | - | 20 | 25 | m Ω |
| | | $V_{GS}=2.5V, I_D=3.5A$ | - | 27 | 32 | m Ω |
| Forward Transconductance | g_{FS} | $V_{DS}=5V, I_D=7A$ | - | 17.7 | - | S |
| Dynamic Characteristics | | | | | | |
| Input Capacitance | C_{iss} | $V_{DS}=8V,$ $V_{GS}=0V,$ $F=1.0MHz$ | - | 802 | - | pF |
| Output Capacitance | C_{oss} | | - | 153 | - | pF |
| Reverse Transfer Capacitance | C_{rss} | | - | 122 | - | pF |
| Switching Characteristics | | | | | | |
| Turn-on Delay Time | $t_{d(on)}$ | $V_{DD}=10V,$ $I_D=1A$ $V_{GS}=4.5V,$ $R_{GEN}=10\Omega,$ $R_L=10\Omega$ | - | 18 | - | nS |
| Turn-on Rise Time | t_r | | - | 5 | - | nS |
| Turn-Off Delay Time | $t_{d(off)}$ | | - | 43.8 | - | nS |
| Turn-Off Fall Time | t_f | | - | 20 | - | nS |
| Total Gate Charge | Q_g | $V_{DS}=10V,$ $I_D=4A,$ $V_{GS}=4.5V$ | - | 10.5 | - | nC |
| Gate-Source Charge | Q_{gs} | | - | 2 | - | nC |
| Gate-Drain Charge | Q_{gd} | | - | 2.5 | - | nC |
| Drain-Source Diode Characteristics | | | | | | |
| Diode Forward Voltage | V_{SD} | $V_{GS}=0V, I_S=1.7A$ | - | - | 1.2 | V |

Notes:

- Surface Mounted on FR4 Board ,T<10 sec ;
- Pulse Test: Pulse Width $\leq 300 \mu s$, Duty Cycle $\leq 2\%$.
- Guaranteed by Design, not subject to production testing.



TYPICAL ELECTRICAL AND THERMAL CHARACTERISTICS

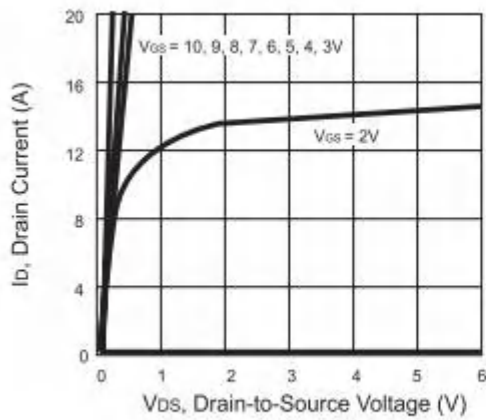

Figure 1. Output Characteristics

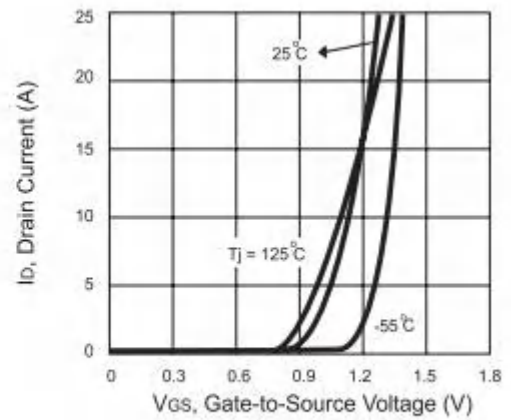

Figure 2. Transfer Characteristics

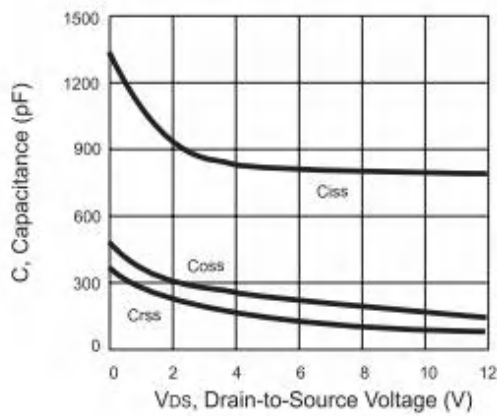

Figure 3. Capacitance

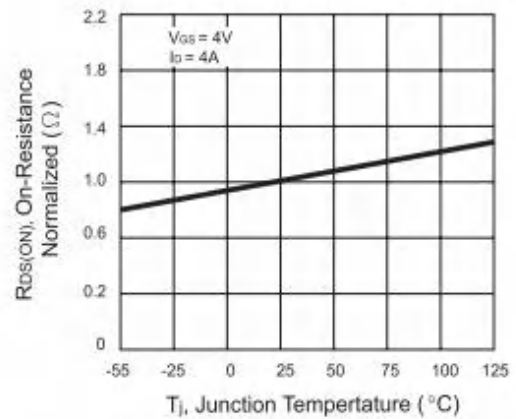

Figure 4. On-Resistance Variation with Temperature

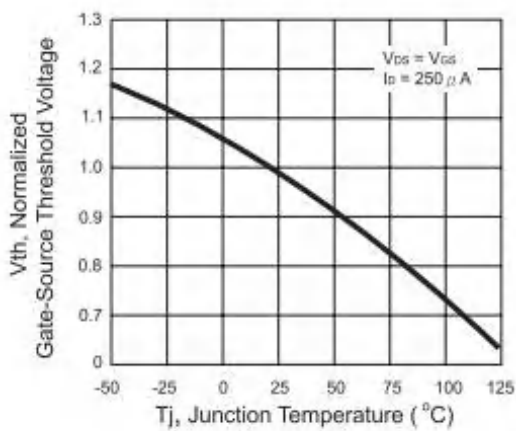

Figure 5. Gate Threshold Variation with Temperature

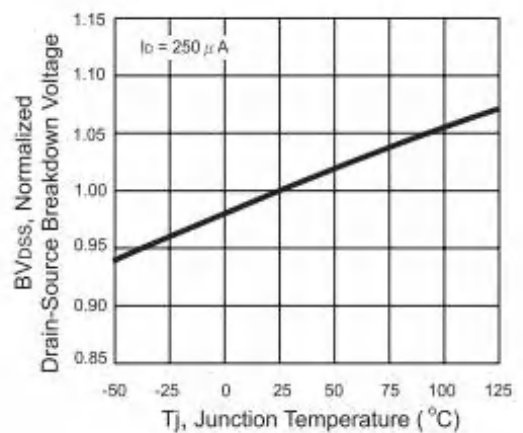

Figure 6. Breakdown Voltage Variation with Temperature

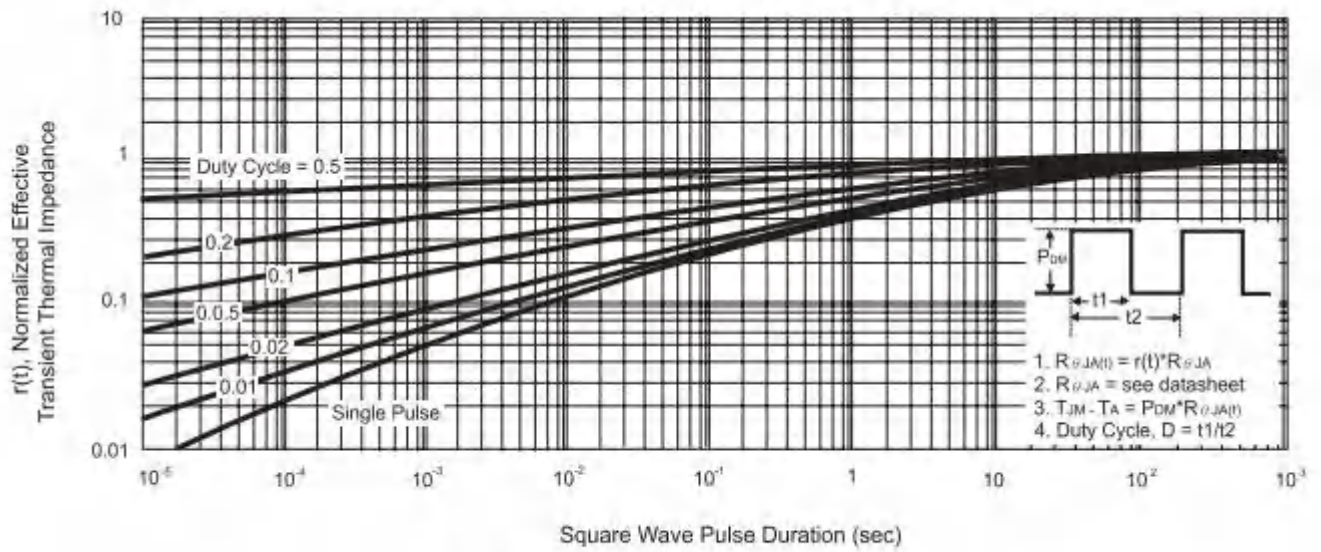
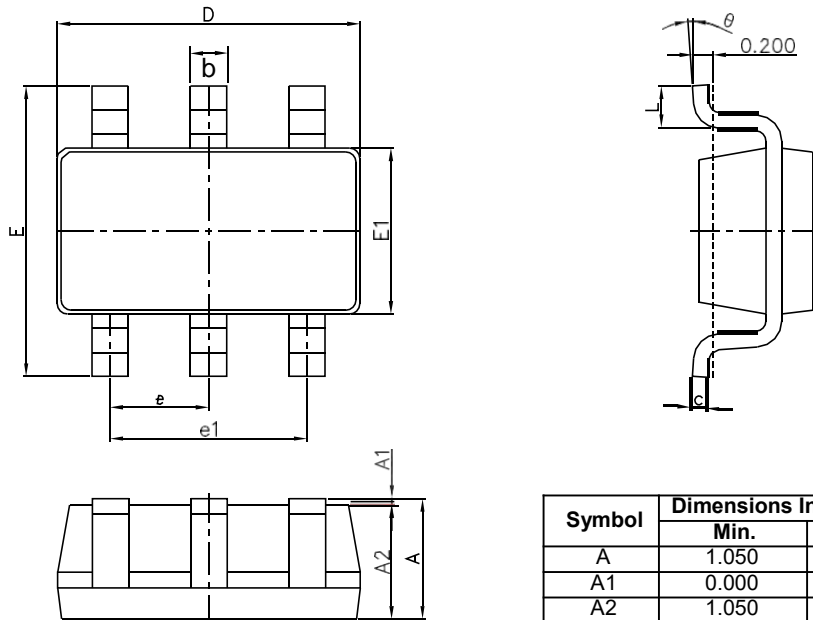

Figure 13. Normalized Thermal Transient Impedance Curve



SOT-23-6L Package Outline Dimensions



| Symbol | Dimensions In Millimeters | | Dimensions In Inches | |
|--------|---------------------------|-------|----------------------|-------|
| | Min. | Max. | Min. | Max. |
| A | 1.050 | 1.250 | 0.041 | 0.049 |
| A1 | 0.000 | 0.100 | 0.000 | 0.004 |
| A2 | 1.050 | 1.150 | 0.041 | 0.045 |
| b | 0.300 | 0.500 | 0.012 | 0.020 |
| c | 0.100 | 0.200 | 0.004 | 0.008 |
| D | 2.820 | 3.020 | 0.111 | 0.119 |
| E1 | 1.500 | 1.700 | 0.059 | 0.067 |
| E | 2.650 | 2.950 | 0.104 | 0.116 |
| e | 0.950(BSC) | | 0.037(BSC) | |
| e1 | 1.800 | 2.000 | 0.071 | 0.079 |
| L | 0.300 | 0.600 | 0.012 | 0.024 |
| θ | 0° | 8° | 0° | 8° |

SOT-23-6L Suggested Pad Layout

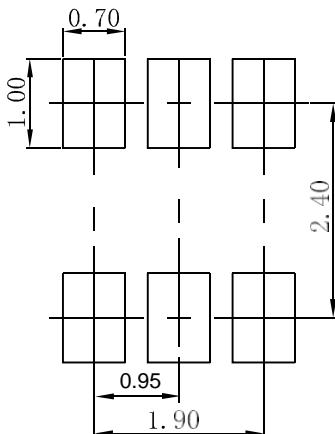

Note:

1. Controlling dimension: in millimeters.
2. General tolerance: $\pm 0.05\text{mm}$.
3. The pad layout is for reference purposes only.